



## **CMHB** Cooling Only/Heat Pump Nominal Circuits: 9,000 - 48,000 BTU/h



### **Description**

The **Comfort-Aire CMHB** is a highly effective ceiling mounted evaporator for applications where fully exposed or partially recessed cabinetry can be used. For partially recessed mounting, these units easily adapt to standard T-bar, drop ceiling openings. The **CMHB** is designed for residential applications where the unit may be concealed in soffits or other structural spaces with only the intake and discharge grilles exposed.

The aluminum supply air louvers are dual adjustable for air flow direction, to provide air flow throws to suit any installation. The louvers are mounted in an attractive high impact polystyrene front section. The **CMHB**s incorporate dual blowers that produce efficient quiet operation suitable for both residential and commercial applications. A wide range of options are available for the **CMHB** units, including supplemental electric or hydronic heat options, a field installed condensate pump, and optional digital and hand held IR remote controls (straight cool only).

The **CMHB** (Heat Pump) models are two stage heating units when back up resistance heat is supplied.

The **CMHB** models are fast and easy to install with 24V control circuits to the outside unit, standard. Hanger brackets and fresh air openings are standard on all models. Optional trim kits are available for surface mounting applications.

The **CMHB** models are equipped, as standard, with 24V control circuits to the outside for surface mounting applications.

All **Comfort-Aire** products are subject to ongoing development programs and design and specifications may change without notice.

### **Capacities/Efficiencies:**

The **CMHB** ceiling mounted evaporators produce system SEER's exceeding 10.0. (See the **Comfort-Aire** System Configuration Chart for a specific data with all **Comfort-Aire** outdoor units)

### **Materials of Construction**

#### **Cabinet:**

- Fabricated of 20 gauge galvalume steel
- Powder coated finish
- High impact polystyrene air discharge panel

#### **Intake Grille:**

- Removable, perforated steel inlet grille

#### **Discharge Grille Assembly:**

- Adjustable, aluminum bidirectional louvers

#### **Condensate Drain Pipe:**

- Galvanized Steel with anti-corrosion coating

#### **Colours:**

- Cabinet: matte finish, designer white
- Discharge Vanes-aluminum

### **Air Systems**

#### **Fan/Motor:**

- Fans are forward curve, centrifugal type, directly mounted to the motor's shafts and dynamically balanced
- Motor: PSC type with internal thermal overload protection
- Air stream surfaces are insulated with 1/4" fiberglass and 1/2" foil face insulation

### **Coil**

Coil is seamless, copper tubing, arranged in staggered configuration, with enhanced aluminum fins, tested to 460 psig. The tubes are mechanically expanded for secure bonding to fin shoulder.

### **Refrigeration Circuit**

The units are equipped with Chatleff/Piston expansion device. Connections are male flare type, diameters per table (reverse side).

### **Controls/Components**

Controls and Components installed at the factory or supplied include:

- Connections for 24V thermostat
- Custom developed control board featuring anti-short cycle timer, 60 second post purge fan relay and on-board 30 amp electric heat relay
- Open wire electric heaters used on all sizes, all with automatic reset high temperature cut-out and redundant high temperature fuse link
- Heat Pump circuits equipped with crankcase heater

### **System Options**

- Electric heat options
- Hydronic heating coil, one row type
- 24V, Mercury Bulb Thermostat
- Digital control for programmed operation, with cable interconnect (straight cool only, factory installed control module required)
- Hand held IR remote control (cooling only)
- Installation isolator kit
- Hanger Bolt cover kit
- Condensate Pump (MCP field installed)
- Hydronic heat coil with sweat connections factory supplied motorized valves

**The Ductless Split Systems of Choice**



# CMHB

## Dimensions and Specifications

### CMHB Discharge Air Speed & Throw

MODEL	CFM HI/LO	COIL	FPM	THROW/FT.
09, 12	350	Dry	290	12.4
15	450	Dry	375	12.4
18	650	Dry	430	18.6
24, 30	800	Dry	533	18.6
36, 42, 48	1200/1050	Dry	500	19

### CMHB With Electric Heat Options

MODEL	VOLTAGE	KW	HEATER AMPS	TOTAL AMPS	MIN CIR AMPS	MAX FUSE
09, 12, 15	208/230	3	13.1	13.7	17.1	20
09, 12, 15	208/230	4	17.4	18	22.6	25
18, 24, 30	208/230	5	21.7	22.8	28.5	30
18, 24, 30	208/230	7	30.4	31.5	39.5	40
36, 42, 48	208/230	7	30.4	32.6	40.5	45

### CMHB Observed Sound Values, 230V Low Speed Fan

MODEL	BELS
09, 12, 15	5.7
18, 24, 30	6.4
36, 42, 48	6.5

### CMHB Electrical Specifications

MODEL	VOLTAGE	HERTZ	FAN FLA	MIN (1) AMPACITY	MAX (1) FUSE
CMHB09	208/230	60	.6	.8	15
CMHB12	208/230	60	.6	.8	15
CMHB15	208/230	60	.6	.8	15
CMHB18	208/230	60	1.1	1.4	15
CMHB24	208/230	60	1.1	1.4	15
CMHB30	208/230	60	1.1	1.4	15
CMHB36	208/230	60	1.1/1.1	2.5	15
CMHB42	208/230	60	1.1/1.1	2.5	15
CMHB48	208/230	60	1.1/1.1	2.5	15

### CMHB

#### Physical Dimensions and Piping Specifications

(1) If electric heaters are installed, use ampacity rating and max fuse from Heater Options Chart.

MODEL	WIDTH "A"	WIDTH "B"	HEIGHT "C"	WIDTH "D"	WIDTH "E"	DRAIN HOSE	SHIP WT.	REF LINE SIZES	
								LIQUID	SUCTION
09, 12	42"	16 1/2"	10 3/4"	41"	5 1/2"	1/2" I.D.	115	1/4"	1/2"
15	42"	16 1/2"	10 3/4"	41"	5 1/2"	5/8" I.D.	135	1/4"	5/8"
18	49"	19"	10 3/4"	48"	5 1/2"	5/8" I.D.	135	3/8"	5/8"
24	49"	19"	10 3/4"	48"	5 1/2"	5/8" I.D.	135	3/8"	3/4"
30	49"	19"	10 3/4"	48"	5 1/2"	5/8" I.D.	135	3/8"	3/4"
36,42,48	59"	16 1/8"	12 3/4"	58"	7 1/2"	5/8" I.D.	160	3/8"	7/8"

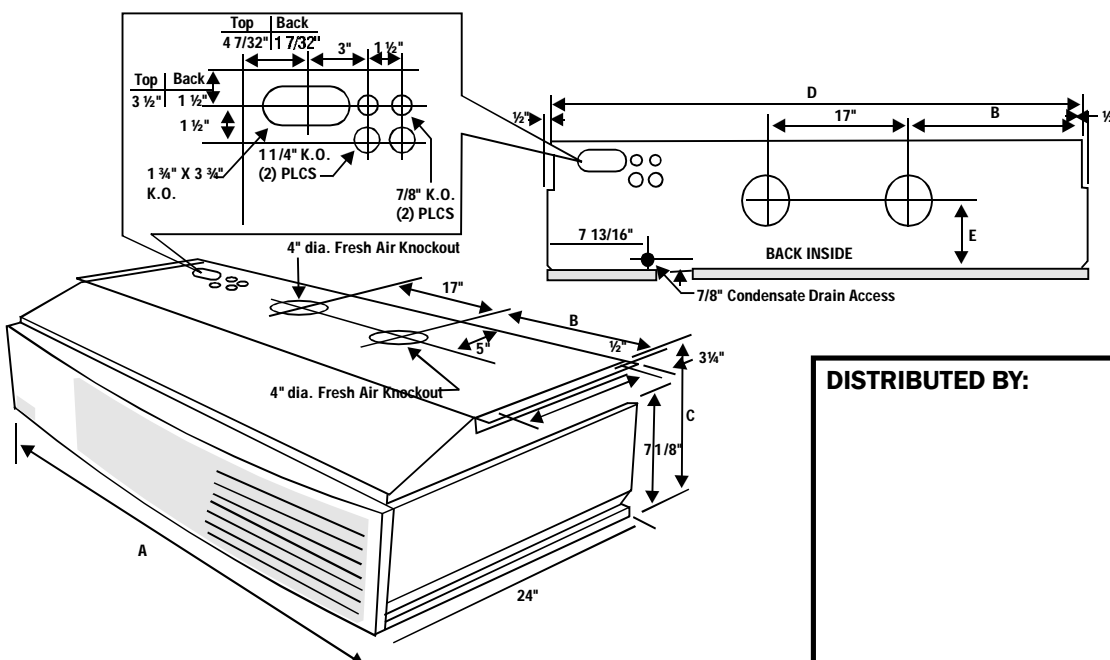

**AITONS' EQUIPMENT INC.**  
**519-824-2911**  
[www.aitons.com](http://www.aitons.com)  
[www.comfort-aire.com](http://www.comfort-aire.com)  
 e-mail: [info@aitons.com](mailto:info@aitons.com)

**DISTRIBUTED BY:**